

Ka Band Block Upconverter (BUC) 27.5 to 30GHz, 8W

LW30-797777

TYPICAL APPLICATIONS

- Next generation Sat Comm Systems
- Airborne applications
- Man pack/Flyaway applications

PRODUCT FEATURES

- IESS 308/309 compliant
- Adjustable gain
- Temperature compensated
- GUI controlled (RS-422 protocol)
- iDirect OpenBMIP™ Standard compatible
- Integral high performance output filtering

GENERAL DESCRIPTION

The LW30-797777 is a high performance power BUC with an integral driver and GaN power amplifier sections. The design allows for flexibility in the customers' requirements with a number additional features being available.

Extended temperature range and harsh environment models are also available. Please contact factory for alternative connector and frequency options.



ELECTRICAL CHARACTERISTICS - Operational $T_A = 25\text{ }^\circ\text{C}$, 50 Ω System (unless otherwise noted)

PARAMETER	MIN	TYP	MAX	UNITS
IF Input frequency	950		1950	MHz
Output Frequency Band 0	27.5		28.5	GHz
Output Frequency Band 1	28.0		29.0	GHz
Output Frequency Band 2	29.0		30.0	GHz
Maximum Operating Power (MOP)		39		dBm
Conversion gain at MOP		65		dB
ACPR at MOP (BPSK, 1Msps, $\alpha=0.2$, 1.2MHz integration bandwidth, 1.2MHz offset from centre frequency)			-20	dBc
Input Return Loss		14		dB
Output Return Loss (Integrated Isolator)		14		dB
Noise Figure (maximum gain)		8		dB
Gain ripple over frequency (1GHz band, fixed temp at MOP)			3	dB p-p
Gain ripple over temperature (fixed frequency at MOP)			3	dB p-p

Linwave reserves the right to make changes, without notice, in the products, including circuits, standard cells, and/or software, described or contained herein in order to improve design and/or performance.

PARAMETER	MIN	TYP	MAX	UNITS
Gain Control range (IF input attenuator)		20		dB
Spurious Outputs (Signal related in band)		-60		dBc
Spurious Outputs (LO leakage)		-45		dBc
Frequency reference (external on L band input)		50		MHz
Phase Noise 100Hz offset from carrier			-50	dBc/Hz
1kHz offset from carrier			-75	dBc/Hz
10kHz offset from carrier			-85	dBc/Hz
100kHz offset from carrier			-95	dBc/Hz
1MHz offset from carrier			-105	dBc/Hz
10MHz offset from carrier			-112	dBc/Hz
Power Consumption at MOP (+28V supply)			105	W
Operating temperature range	-40		70	°C
Storage temperature range	-40		85	°C

MECHANICAL CHARACTERISTICS

PARAMETER	VALUE	UNITS
Dimensions (typ)	180 x 130 x 25 (L x W x H) main BUC housing (Excluding mounting lugs and WG Isolator output)	mm
Weight (max)	1.1	kg
IF/RF connectors	IF - SMA female, RF – WR28 (WG22)	-
Control/Power connector	15 pin Micro D socket	-
Cooling	Conduction cooled through the baseplate	-

PERFORMANCE DATA

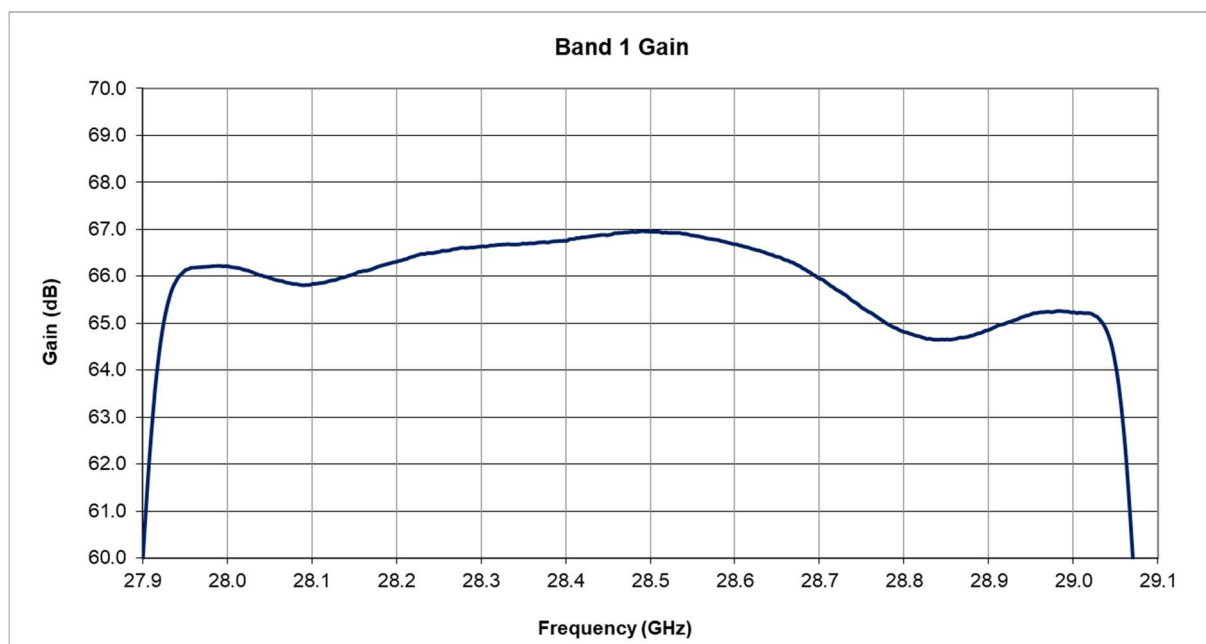

Linwave reserves the right to make changes, without notice, in the products, including circuits, standard cells, and/or software, described or contained herein in order to improve design and/or performance.

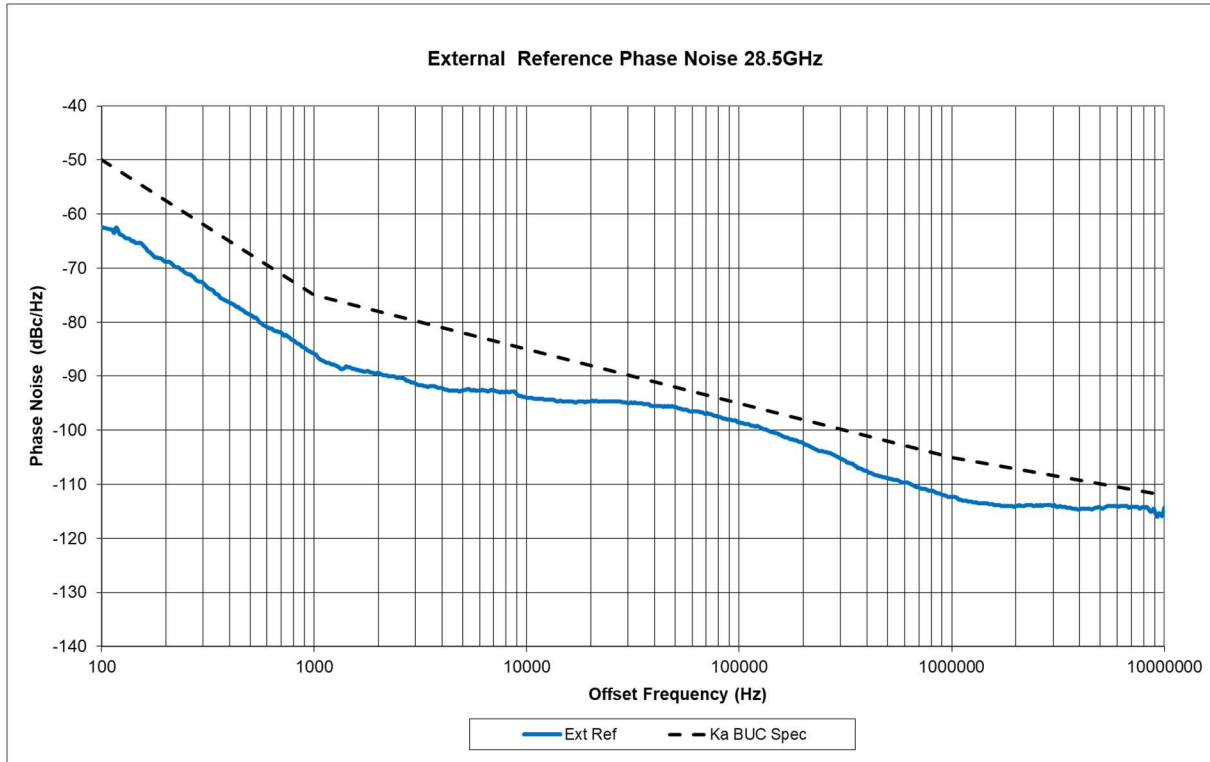

MECHANICAL OUTLINE

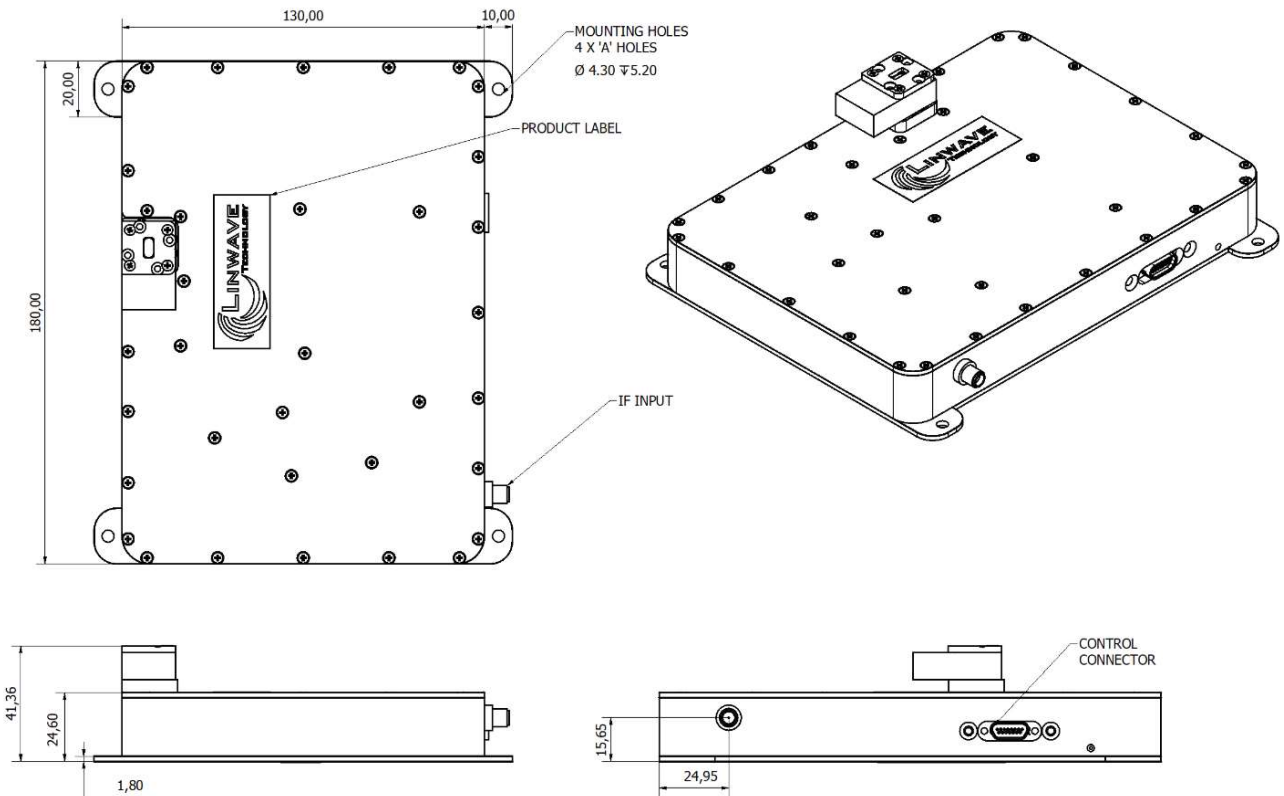

Linwave reserves the right to make changes, without notice, in the products, including circuits, standard cells, and/or software, described or contained herein in order to improve design and/or performance.