

KU PM BB 0104000 B

100 MHz – 40 GHz Powermeter



Manual

*illustrations similar

Technical data – KU PM BB 0104000 B

Frequency range:		100 MHz ... 40 GHz
Dynamic range, 1 dB-error (at 20 °C):	(100 MHz ... 30 GHz) (30 GHz ... 40 GHz)	-35 dBm ... 0 dBm -25 dBm ... 0 dBm
Detector characteristic:		Envelope
Absolute maximum RF input power:		10 dBm
Return loss:		typ. 10 dB
Operating temperature range: (Reduced accuracy at temperatures below 0 °C or above 40 °C !)		0 °C ... 40 °C
Crosstalk attenuation:		typ. > 40 dB
Supply voltage:		+5 V DC (USB-C)
Current consumption:		typ. 500 mA
PoE-standard:		803.11af
RF connector type:		RPC2.92-female, 50 Ω
Network interface:		RJ45, Ethernet
Data interface:		HTTP (web-interface) SNMP, JSON (raw data)
Acquisition rate:		1 Sample / Second
Dimensions:		115 x 80 x 42 mm
Weight:		typ. 260 g

*We reserve the right to make technical changes without prior notice

Features

- Displaying of IP address and measurement data on LCD screen
- Real-time data monitoring via web interface
- Long-term monitoring by data recording in internal memory, visualization in web interface or download as csv file
- Easy to use API for data readout
- Alarm function

Applications

- Tests and measurements
- System monitoring (real-time/long-term)



Kuhne electronic GmbH

Scheibenacker 3 Telefon: +49 (0) 9293 / 800640
 95180 Berg – Germany E-Mail: info@kuhne-electronic.de



Technical Drawing

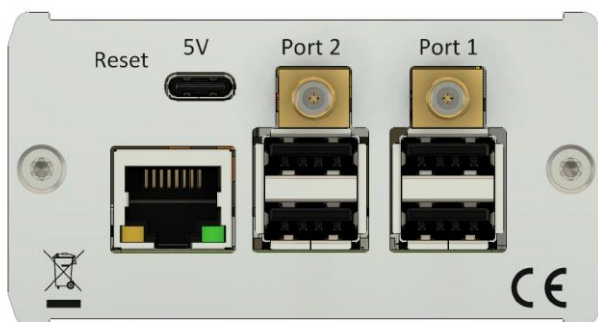
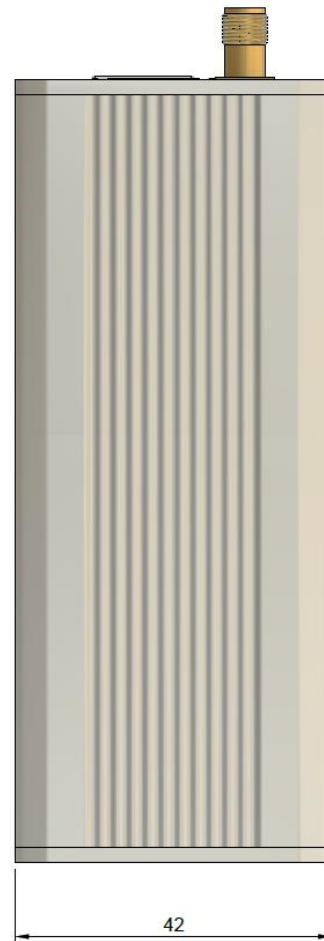
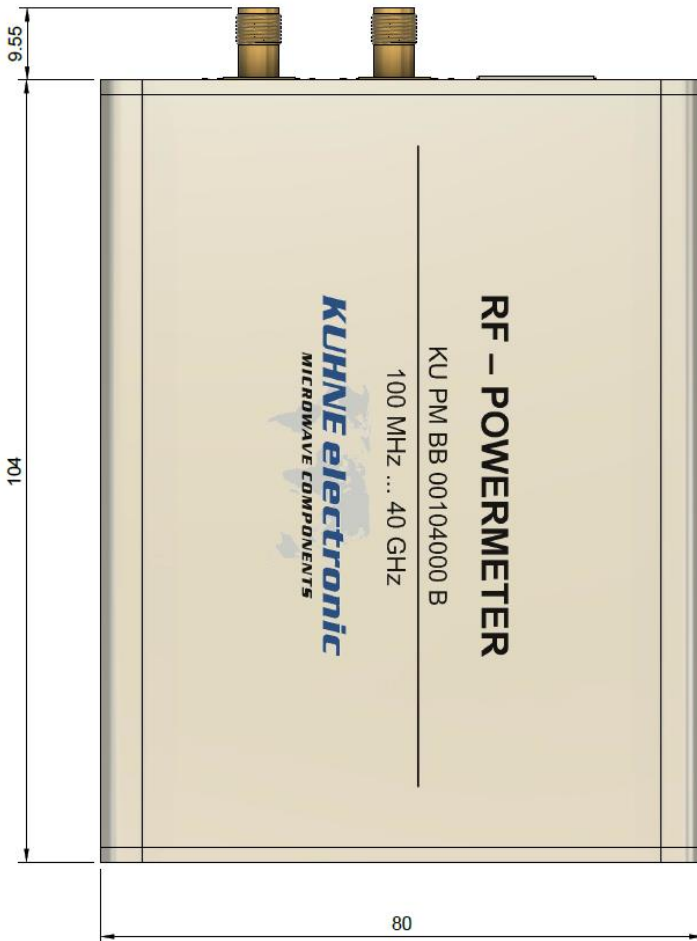

General description

The KU PM BB 0104000 B is a cost-effective RF power meter covering the frequency range from 100 MHz to 40 GHz. It features 2 independent measurement channels, which cover a dynamic range from -35 to 0 dBm. The device is designed for standalone use as well as for operation in monitoring systems. The measured values are displayed directly on the device, but can also be accessed over Ethernet. In the web interface, the values can be displayed in real time or saved over a longer period of time and exported as a CSV file.

The configuration of the device is also performed using the web interface. For integration into monitoring systems, it is also possible to query the data via the SNMP interface or via HTTP in JSON format. Furthermore, alarm thresholds can be configured in the device. If these thresholds are exceeded, an alarm can be issued via an SNMP-TRAP or an HTTP-request. For easier localization the color of the LCD backlight changes depending on the alarm state.

This manual describes the operation of the device. A separate programmers guide for using the API is also available .

Connectors and Indicators



- (1) Device name (factory default: KUPMBB0104000B; user settable)
- (2) Device IP-Address (factory default: 10.10.10.10; user settable)
- (3) Channel name (factory default: Port 1/2; user settable)
- (4) Measured value in dBm

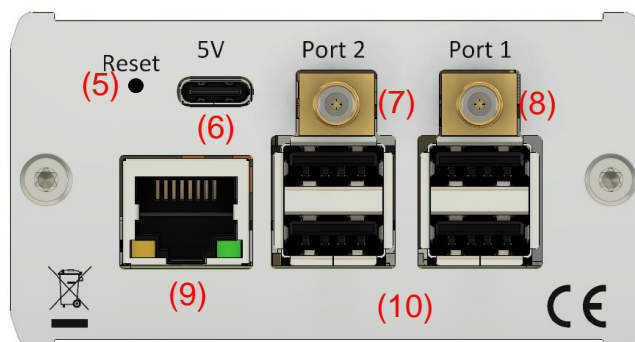

- (5) Reset button, resets the network configuration to factory settings.
- (6) USB-C socket for 5 V DC supply
- (7) 2.92mm port for channel 2
- (8) 2.92mm port for channel 1
- (9) LAN interface with PoE support
- (10) USB interfaces

Quick Setup

- 1) Connect a USB-C power supply or an Ethernet cable that provides power over Ethernet (PoE) according to the IEEE 803.11af standard. Then connect the 2.92 mm connector cables that carry the RF signal to be measured.
- 2) After connecting the power supply and a waiting time of 10 seconds, the display turns red for approx. 8 seconds
- 3) After steps 1 and 2, display will show the screen described in the previous section.

Web Interface

To access to the web interface, connect the powermeter LAN interface (9) on page 4 with a valid network host

Now open your web browser and enter the IP address indicated on the display (10.10.10.10 by default). You can change the IP address afterwards.

Note: Make sure that the network settings of your PC allow a connection to the IP address of the powermeter (PC and powermeter must be in the same net).

The connection with the powermeter should now be established and your web browser will display the measurement in real time as shown on page 10.

Status-Tab (1)

The Status tab shows the current settings and measured values of the device. All settings shown here can be queried easily using the API provided. For details, please refer to the programming instructions.

KUPMBB001800A		Status	Measurement	Export Data	Calibration	Settings ▾
Values						
(1)	Measured Value of Port 1:					-83.02 dBm
(2)	Measured Value of Port 2:					-81.99 dBm
(3)	Date and Time of last Measurement					Mon, 14 Jun 2021 07:48:29
(4)	Alarm Status of Port 1:					0
(5)	Alarm Status of Port 2:					0
(6)	Combined Alarm Status:					0
Model Information						
(7)	Model ID:					KU PM BB 001800A
(8)	Serial Number:					00000000
(9)	Installed Firmware Version:					1.0
Device Settings						
(10)	Name:					KUPMBB001800A
	Location:					somewhere over the rainbow
	Point of Contact:					Michael Loose
(11)	IPv4 Address:					192.168.0.129
	Subnet Mask:					255.255.255.0
	Gateway:					192.168.0.1
(12)	MAC Address:					b8:27:eb:3f:0f:8f
(13)	Online Since:					Mon, 14 Jun 2021 05:38:22
(14)	Record Status:					False
	Record Running Since:					Not Running
	Record Measured Points:					Not Running
(15)	Acquisition Mode:					MEAN
(16)	Maximum File Length:					100000
(17)	Display Color:					#00FF00 ■
	Display Color at Warning:					#FFFF00 ■
	Display Color at Alarm:					#FF0000 ■
(18)	Alarm Settings					
	Alarm via SNMP-Trap Active:					True
	SNMP-Manager IP:					192.168.0.101
	SNMP-Manager Port:					162
	Alarm via HTTP-Request Active:					False
	HTTP-Request Alarm URL:					http://192.168.0.102:5000
	HTTP-Request Type:					POST
	Alarm Repetition Interval [s]:					0

Status-Tab (1)

- (1) Currently measured power at port 1
- (2) Currently measured power at port 2
- (3) Time of the last measured value
- (4) Alarm state of port 1
- (5) Alarm state of port 2
- (6) Combined alarm status (The highest alarm state of both channels)
Alarm state: (0: OK | 1: Alarm | 2: Warning)
- (7) The Product-ID of the device
- (8) The serial number of the device
- (9) The installed firmware version
- (10) The user settable device information
- (11) The network configuration
- (12) The MAC address of your device
- (13) Date and time since the device has been connected to the DC power supply
- (14) Information about the current recording (Active, Active since, number of measured points)
- (15) Acquisition Mode (Please see page 17 for details)
- (16) Maximum length of a recording file
- (17) Configured display colors
- (18) Alarm configuration (Please see page 19 for details)

Status-Tab (2)

Time		
(1)	Local time:	Mon 2021-06-14 07:47:47 UTC
(2)	Universal Time:	Mon 2021-06-14 07:47:47 UTC
(3)	RTC Time:	Mon 2021-06-14 07:47:47
(4)	Time Zone:	Etc/UTC (UTC, +0000)
(5)	NTP Active:	False
(6)	NTP Primary Server:	ptbtime1.ptb.de
(7)	NTP Fallback Server:	ptbtime2.ptb.de
Port 1		
(8)	Port 1 Name:	Port 1
(9)	Port 1 Frequency:	1000 MHz
(10)	Port 1 Offset:	2.0 dB
(11)	Port 1 Low Warning Level:	-200.0 dBm
	Port 1 Low Alarm Level:	-200.0 dBm
	Port 1 High Warning Level:	200.0 dBm
	Port 1 High Alarm Level:	200.0 dBm
(12)	Port 1 Calibration Datetime:	Fri, 26 Mar 2021 11:52
(13)	Port 1 Calibration Location:	Kuhne electronic GmbH
Port 2		
	Port 2 Name:	Port 2
	Port 2 Frequency:	1000 MHz
	Port 2 Offset:	-3.0 dB
	Port 2 Low Warning Level:	-200.0 dBm
	Port 2 Low Alarm Level:	-200.0 dBm
	Port 2 High Warning Level:	200.0 dBm
	Port 2 High Alarm Level:	200.0 dBm
	Port 2 Calibration Datetime:	Fri, 26 Mar 2021 12:08
	Port 2 Calibration Location:	Kuhne electronic GmbH

Status-Tab (2)

- (1) The system time in the configured local time zone
- (2) The system time as coordinated universal time (UTC)
- (3) The time on the real-time clock IC of the device
- (4) The configured time zone
- (5) The status of the network time protocol (NTP) service
- (6) The configured primary time server
- (7) The configured secondary time server
- (8) The configured name of port 1
- (9) The configured frequency to be used for the correction coefficients
- (10) The configured offset value
- (11) The configured alarm thresholds of port 1
- (12) Date and time of the stored calibration file for port 1
- (13) Calibration location of the stored calibration file for port 1

Measurement-Tab

The Measurement tab displays the measured values and visualizes the trend in an adjustable time span as a graph. In addition, the measurement recording can be started and stopped using the form below. These recordings can be visualized in the web interface and exported to your PC as csv files. (Please see page 12 and 13 for details)

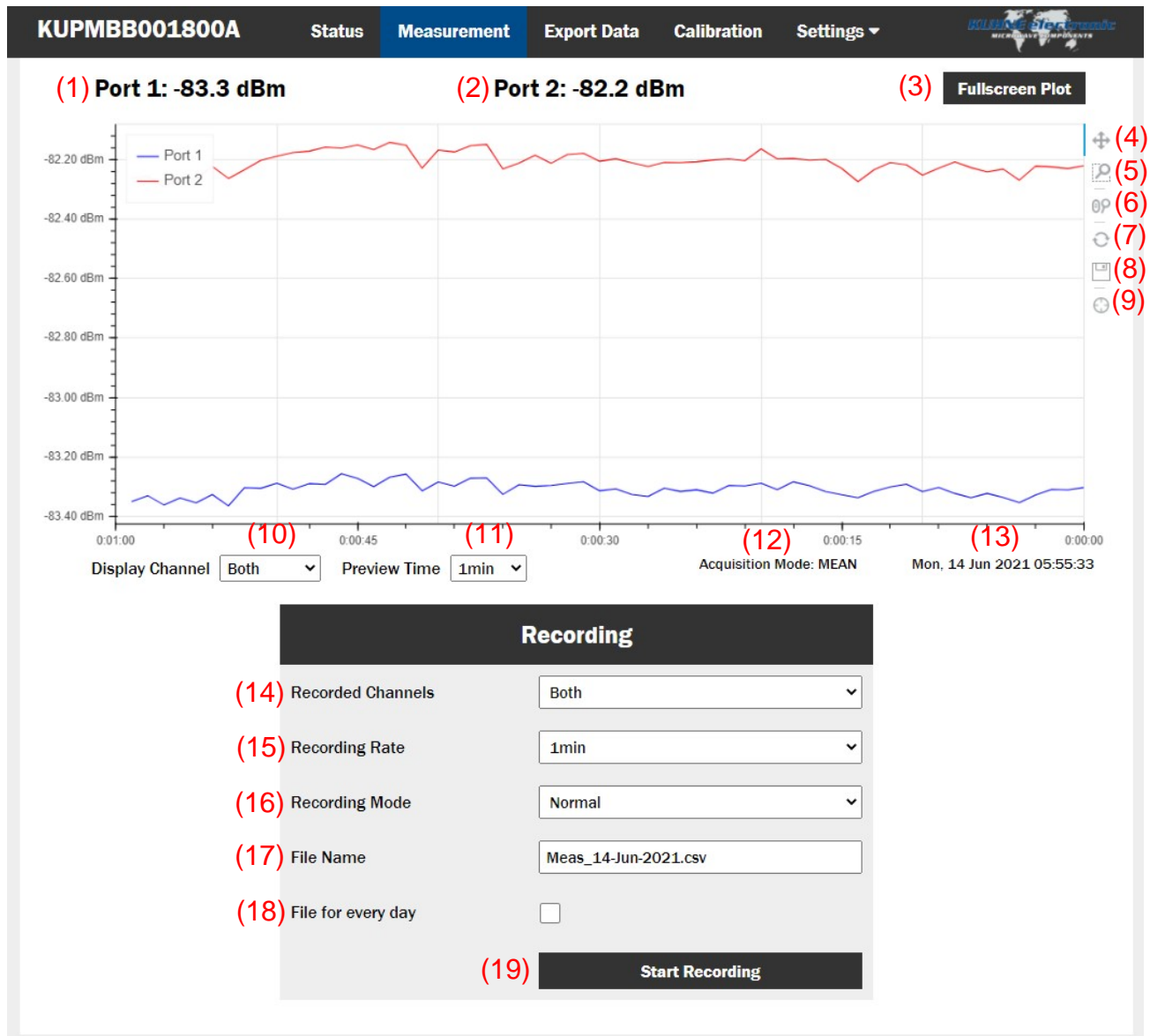

- (1) Currently measured power at port 1
- (2) Currently measured power at port 2
- (3) Displays the graph at fullscreen in a new tab
- (4) Activates pan mode

The view can be moved by keeping the left mouse button pressed within the diagram

(6) Activates the wheel zoom

By turning the mouse wheel you can zoom in and out at the mouse pointers position.

(7) Resets the diagram display to the default settings

(8) Creates a screenshot of the current diagram as a PNG file

(9) Enables the cursor mode

When the cursor moves over the chart, it becomes a cross which highlights the time and power at the cursors position.

(10) Selects which measurement channels are to be displayed

(11) Sets the time span of the measurement diagram

(12) Shows the current acquisition mode (see (8) on page 12 for a detailed description)

(13) Shows the current time and date

(14) Sets the channel whose measured values are to be saved during recording

(15) Changes the recording interval

The recording interval (15) determines, how often a measured value is stored to the recording file. Regardless of this, one value is measured per second. The recording mode (16) determines how the value written to the recording file, is determined from the values measured so far. For example, at a recording interval of 1 minute, one value is being stored to the recording file every 60 measurements.

(16) Changes the recording mode

Normal: the value measured at the time of recording is written to the recording file

Averaging: the average of all measured values between the recording times is written to the recording file

Max Value: the highest value measured between the recording times is written to the recording file

Min Value: the lowest value measured between the recording times is written to the recording file

(17) Changes the name of your recording file saved

(18) Sets the „File for every Day“ function

When this function is activated, a new recording file is created each time a recording is in progress at the beginning of a new day.

(19) Starts or stop the current recording process

Export-Tab

This tab displays all recordings stored on the device including the currently active recording. In addition to the file name, the table also shows the time of the last recorded measured value and the number of measured values stored in the recording.

File Name	Date of last Measurement	Measured Points	Plot	Download	Delete
Meas_09-Jun-2021.csv	Wed, 09 Jun 2021 10:20	5132	Plot	Download	Delete
Meas_09-Jun-2021_1.csv	Wed, 09 Jun 2021 15:20	1	Plot	Download	Delete
Meas_10-Jun-2021.csv	Thu, 10 Jun 2021 07:54	29	Plot	Download	Delete

By clicking on the "Plot" button of a specific recording the corresponding file is visualized in a separate window (see picture below). By moving the cursor within the diagram, the corresponding data of the respective measured value is displayed (input channel, date, time and power). You can exit the diagram display by clicking on one of the tabs or by using the "Page back" button of your browser. The download button saves the selected file to your computer. Pressing the delete button removes the saved file from the device.

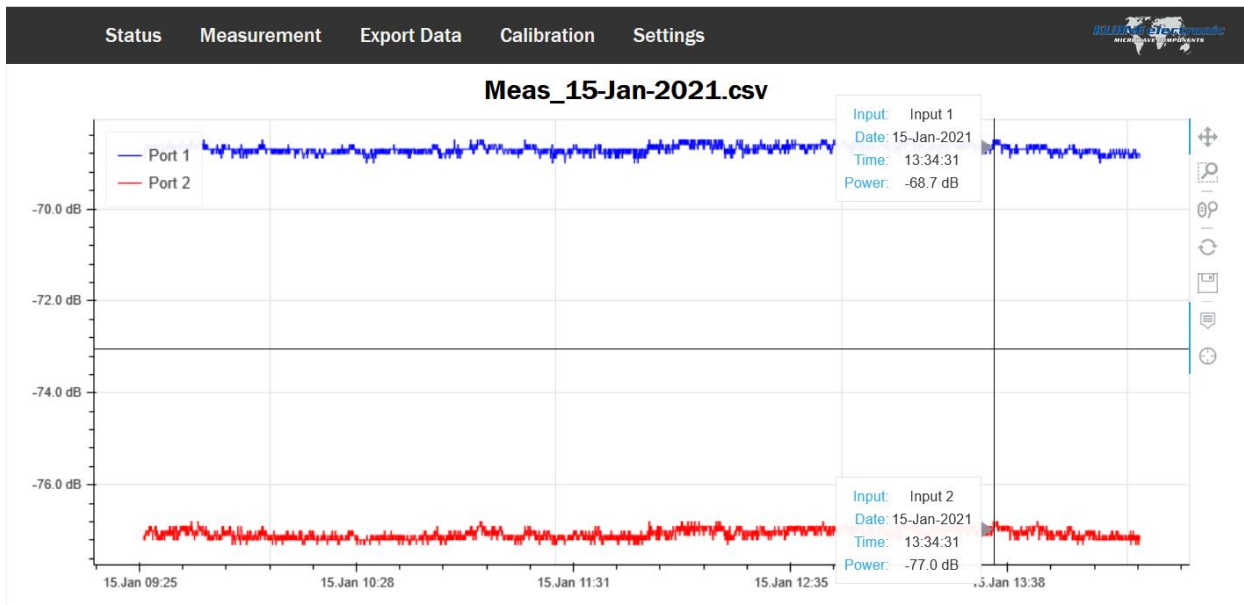

Recorded file

In the Export tab the recorded file can be downloaded to your PC. The picture below shows the structure of the csv file (opened with Microsoft Excel).

	A	B	C	D	E	F	G
1	Number	Date and Time	Port 1	Port 2	RecordingM	AcquisitionMode=MEAN	
2	1	14.06.2021 12:11	-14.91	-78.92			
3	2	14.06.2021 12:12	-14.90	-78.91			
4	3	14.06.2021 12:13	-14.85	-78.85			
5	4	14.06.2021 12:14	-14.90	-78.88			
6	5	14.06.2021 12:15	-14.88	-78.87			
7	6	14.06.2021 12:16	-14.87	-78.86			
8	7	14.06.2021 12:17	-14.91	-78.92			
9	8	14.06.2021 12:18	-14.87	-78.87			
10	9	14.06.2021 12:20	-14.89	-78.89			
11	10	14.06.2021 12:21	-14.89	-78.87			
12	11	14.06.2021 12:22	-14.85	-78.86			
13	12	14.06.2021 12:23	-14.87	-78.86			
14	13	14.06.2021 12:24	-14.88	-78.87			
15	14	14.06.2021 12:25	-14.89	-78.86			
16	15	14.06.2021 12:26	-14.93	-78.91			
17	16	14.06.2021 12:27	-14.84	-78.83			
18	17	14.06.2021 12:28	-14.87	-78.90			
19	18	14.06.2021 12:29	-14.90	-78.90			
20	19	14.06.2021 12:30	-14.91	-78.90			
21	20	14.06.2021 12:31	61.04	-44.13			
22	21	14.06.2021 12:32	61.32	-42.66			

As can be seen in the figure, each recorded measured value is numbered and the time of recording is added. In addition, the recording and acquisition mode used is included at the file header.

A semicolon is used as a column delimiter. The decimal separator is a dot. The raw format looks like this:

```
Number;Date and Time;Port 1;Port 2;RecordingMode=Normal;AcquisitionMode=MEAN
1;14-Jun-2021 10:40:50;47.60;-64.39
2;14-Jun-2021 10:41:53;47.39;-61.37
3;14-Jun-2021 10:42:56;47.54;-67.42
```

Calibration-Tab

In the Calibration tab you can select the frequency to be used for calculating the calibration coefficients. This allows you to achieve a significantly higher measurement accuracy. You can also specify an offset value e.g to compensate for attenuation due to cable losses or coupling factors. Calibration data can also be uploaded here in consultation with the manufacturer.

KUPMBB001800A Status Measurement Export Data **Calibration** Settings ▾

Calibration

Calibration Settings

(1) Port1 Frequency: 1000 MHz

Port2 Frequency: 1000 MHz

(2) Port1 Offset [dB]: 0.0

Port2 Offset [dB]: 0.0

Save Settings

Calibration Properties

	Port 1	Port 2
(3) Calibration Date:	Fri, 26 Mar 2021 11:52	Fri, 26 Mar 2021 12:08
Calibration Place:	Kuhne electronic GmbH	Kuhne electronic GmbH

Restore Factory Cal Restore Factory Cal

Upload Calibration Files

(4) Port1 Calibration File: Datei auswählen Keine ausgewählt

Port2 Calibration File: Datei auswählen Keine ausgewählt

Upload

Calibration-Tab

- (1) Here you can set the expected frequency of the input signal for the respective channel. For broadband signals the center frequency should be used.
- (2) Here you can add an offset value to the measurement result. Attenuators must be entered as a positive value, amplifiers as a negative value. This is especially useful if you use an attenuator or a measurement coupler or if your supply line has an attenuation that you do not want to include in your measurement.
- (3) The date and location of the active calibration are displayed at this point. If a calibration has been stored by the user, it can be overwritten here with the factory calibration.
- (4) If necessary, you can assign a new calibration file to the port. The calibration file contains a characterization of the components in the respective measuring channel, as well as some parameters for signal processing. The provision of such a file is done in consultation with the manufacturer if necessary.

Settings-Tab

In the Settings tab you can perform configurations for your powermeter. The items in the drop-down menu lead to the various settings pages.

The "Reboot" button (10) can be used to trigger a manual restart of the device.

The screenshot displays the settings page for a powermeter. The top navigation bar includes tabs for Status, Measurement, Export Data, Calibration, and Settings. The Settings tab is selected, and a dropdown menu is open, showing options: Device, Alarm, Date and Time, Network, Firmware Update, Reboot (10), and Save/Restore. The main settings area is organized into sections: Device Info, Display, Data Acquisition, and Recording. Red circled numbers (1) through (9) highlight specific fields: (1) Device Name, (2) Device Location, (3) Point of Contact, (4) Port1 Alias, (5) Display Color, (6) Display Color at Warning, (7) Display Color at Alarm, (8) Acquisition Mode, and (9) Max File Length. A 'Save Settings' button is located at the bottom of the settings area.

- (1) The device name that can be set by the user; this is shown both in the display and in the web interface. It is limited to 15 ASCII characters
- (2) Device location that can be set by the user
- (3) User-definable contact person
- (4) User-definable name of the two measuring channels (limited to 15 ASCII characters). These are shown on the display as well as in the web interface and are used in the recorded measurement files as unique identifier of the measured value.

The settings (1) to (4) are used to allocate each measuring devices ist measured values. This is especially helpful if many power meters are used in one system.

- (5) Assignes the normal background color of the display
- (6) Assignes the background color of the display if one of the warning conditions is fulfilled
- (7) Assignes the background color of the display if one of the alarm conditions is fulfilled
- (8) Changes the acquisition mode

The powermeter samples the averaged envelope power at a rate of 2 kHz and uses these values to determine a reading every second. The acquisition mode determines how this measured value is calculated from the sampled values.

Mean: Calculates the arithmetic mean of all sampled values. Used to determine the average power. For most measurement tasks this is the most useful setting.

Median: Uses a median filtering on the measured values. In this process, all sampled values are sorted by size and the value at the center is used. This method is particularly robust against noise, but ignores short pulses or signal drops. This mode is recommended for measuring low powers.

Max: Outputs the maximum value of the samples. This corresponds to the peak envelope power.

Min: Outputs the minimum value of the samples. This is useful, for example, to be able to detect very short signal drops.

- (9) Maximum number of values in a recorded file. If this value is exceeded, a new file is created. A consecutive number is appended to the file name. If you wish to view the recording in the web interface, it is recommended not to store more than 100,000 measured values in a single file, otherwise the loading times will be too long.

Alarm Settings

In this window the alarm thresholds as well as the notification methods for alarms and warnings are defined. An active alarm can be queried via the SNMP or HTTP-JSON interface. In addition, the device can also independently report an alarm event via SNMP traps or HTTP requests. For easier physical localization of the device, the alarm state can also be indicated by a change in the color of the LCD backlight. For details on the Alarm API and code examples please refer to the programmers guide.

KUPMBB001800A Status Measurement Export Data Calibration Settings ▾

Alarm Settings

Levels

Port1 Low Warning [dBm] -10.0

Port1 Low Alarm [dBm] -20.0

Port1 High Warning [dBm] 200.0

Port1 High Alarm [dBm] 200.0

Port2 Low Warning [dBm] -200.0

Port2 Low Alarm [dBm] -200.0

Port2 High Warning [dBm] 200.0

Port2 High Alarm [dBm] 200.0

SNMP-Trap

Alarm as SNMP-Trap

SNMP Manager IP 192.168.0.101

SNMP Trap Port 162

HTTP-Request

Alarm as HTTP-Request

HTTP Request Alarm URL http://192.168.0.101:5000

Request Method POST

Alarm Repetition

Alarm Repetition Rate No Repetition

Save Settings

- (1) The upper and lower thresholds for a warning or alarm
- (2) Sending alarm notifications via SNMP traps
- (3) IP address and port of the trap receiver of the SNMP manager
- (4) Sending alarm messages via HTTP requests
- (5) URL des HTTP-Listeners
- (6) HTTP request method

For details and code examples of items (2) to (6), please refer to the programming manual

- (7) Repetition rate of alarm messages. If this option is enabled, active alarms will be resent at the specified rate.

Network settings

The network settings can be managed on this page. The device currently only supports IPv4.

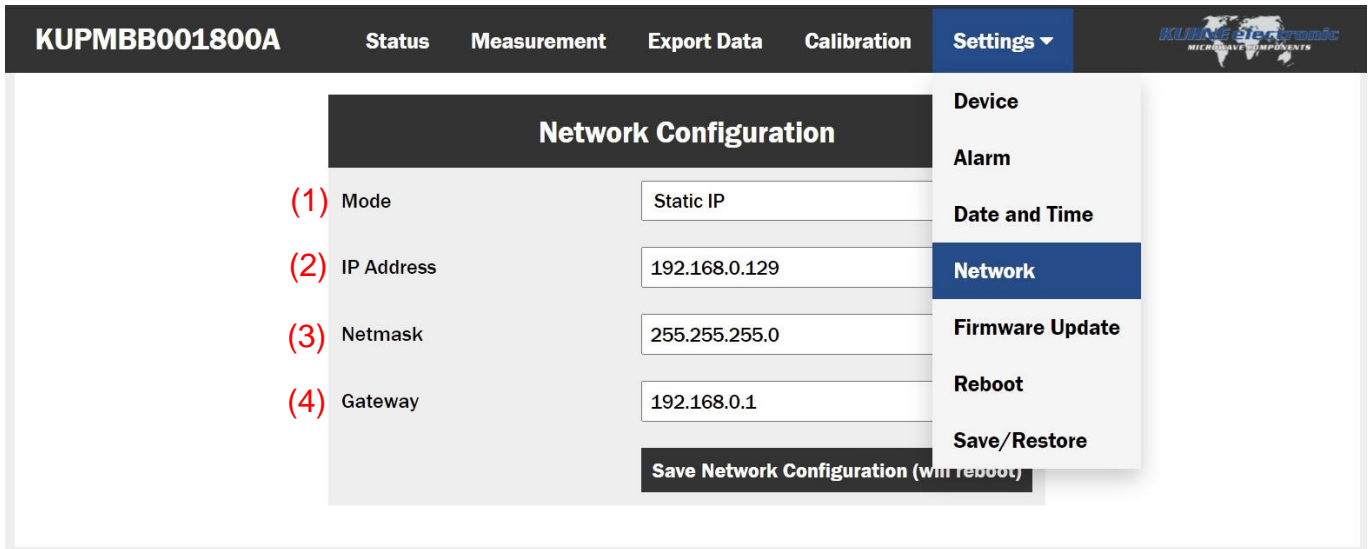

- (1) Configuration mode (static/DHCP)
- (2) IP address of the device (Only for static configuration)
- (3) Netmask of the device (Only for static configuration)
- (4) Default gateway of the device (Only for static configuration)

Be careful when switching from static IP to DHCP! Make sure that a DHCP server is available.

If DHCP is activated, the device tries to obtain an IP address from the DHCP server for 30 seconds after booting. During this time, the display lights up red. If no DHCP server is available after the timeout, the Power Meter will boot up anyway, but will not be accessible via the network. If it is restarted (remove power cable and plug it back in) it will try again to obtain a network configuration from a DHCP-Server.

If you can no longer access your device, press the reset button (see page 4) after the device has fully booted up (readings visible on display) to reset the network configuration to factory defaults. These are:

Mode: static
 IP Address: 10.10.10.10
 Netmask: 255.0.0.0
 Gateway: 10.10.10.1

Date and time settings

On this page, the internal clock of the device can be set, and NTP-Servers can be configured.

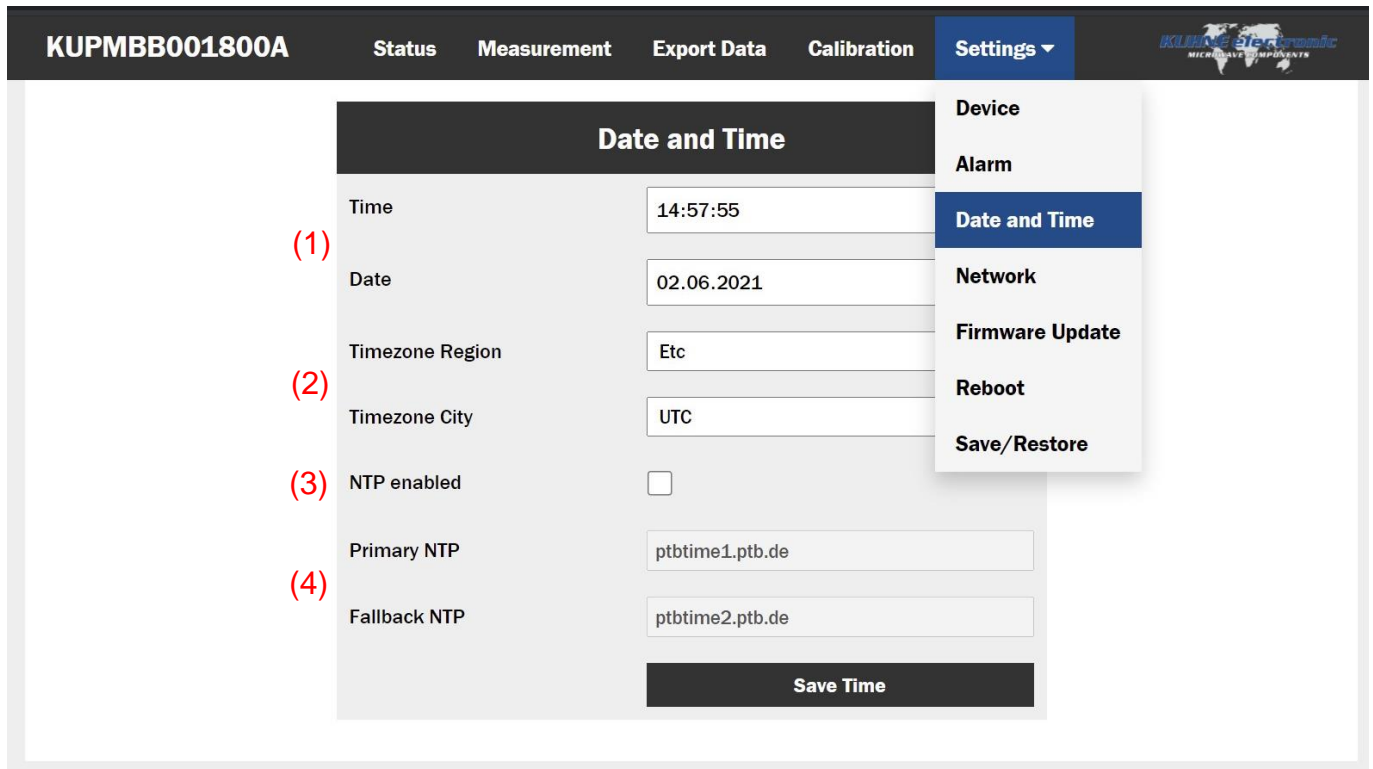

(1) Manual input of the system time

(2) Time zone of the device

(3) Automatic obtaining of the current time via NTP server. If this option is active, manual setting of the original time is deactivated.

(4) IP address of the used NTP server(s)

Attention: If the time zone is changed and NTP is not active, the original time in the fields (1) must already be set in the correct time zone before saving.

Firmware update

Update packages provided by the manufacturer can be installed here.

The screenshot shows the web interface for the KUPMBB001800A power meter. The top navigation bar includes 'Status', 'Measurement', 'Export Data', 'Calibration', and 'Settings'. The 'Settings' menu is open, showing options like 'Device', 'Alarm', 'Date and Time', 'Network', 'Firmware Update' (highlighted), 'Reboot', and 'Save/Restore'. The main content area is titled 'Firmware Update' and contains the following information:

- (1) Product ID: KU PM BB 001800A
- Serial Number:
- File Upload section with a 'Datei auswählen' button and 'Keine ausgewählt' text.
- (2) File upload field.
- (3) Current Firmware: 1.0
- (4) New Firmware: No file provided.
- 'Upload' and 'Install Update' buttons.

- (1) Device information
- (2) Field for uploading the file
- (3) Currently installed firmware version
- (4) Version of the uploaded file

To install an update package, it must first be uploaded via field (2). The Power Meter now checks this package for integrity. If a valid package was detected, the version of the new package is displayed under point (4) and the "Install Update" button is enabled.

Pressing this button starts the update. This may take a few minutes. The device is then restarted automatically. Please make sure that the power supply of the Power Meter stays connected during the installation.

Save and Restore

On this page you can backup the device settings as a file, restore the settings from a backup file, as well as reset the device to factory settings.

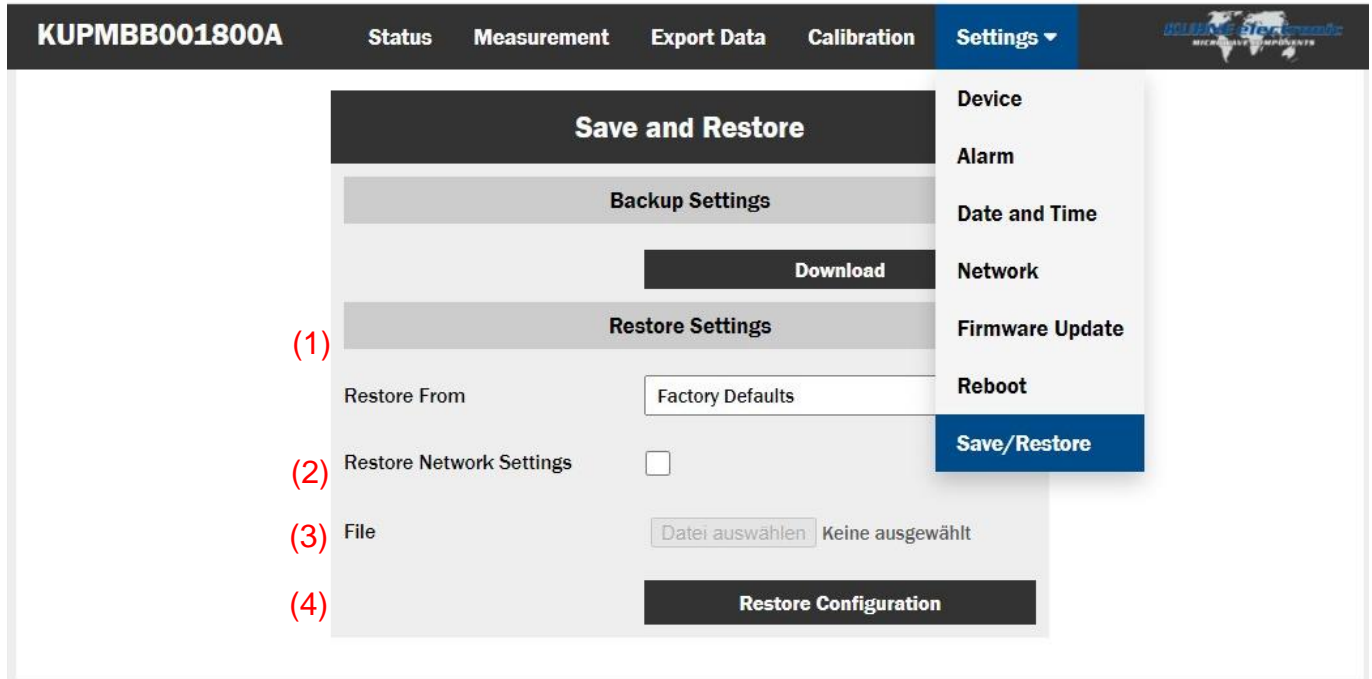

(1) Download the current device settings as a file

(2) Selection of the source from which settings are restored

Factory Defaults: Resets the device to factory settings

File: Restores the settings from an uploaded backup file

(3) Option to restore or keep the network configuration

(4) Field for uploading a backup file

Typical RF Performance

Typical measurement error

temperature

- 0°C
- 10°C
- 20°C
- 30°C
- 40°C

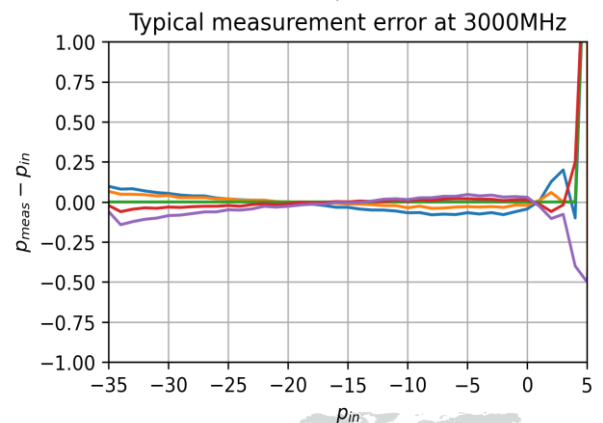
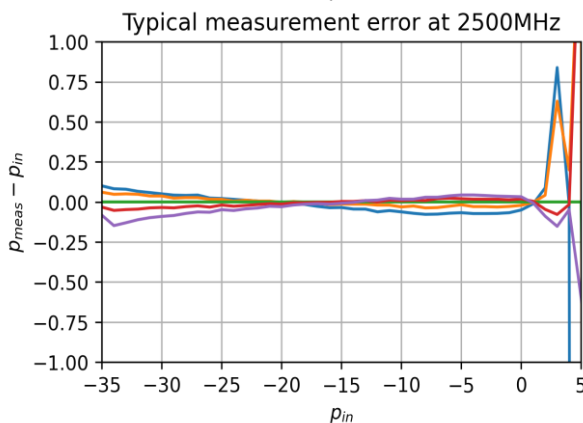
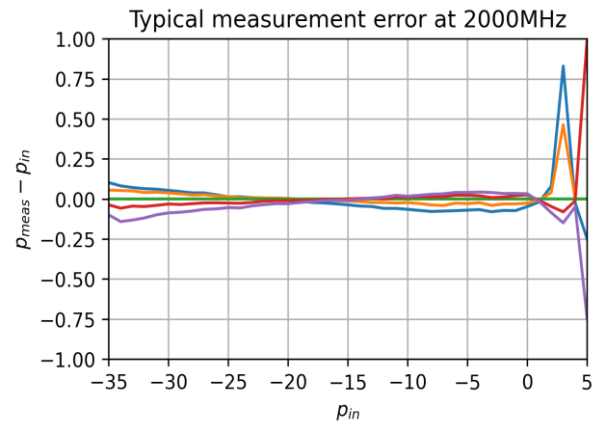
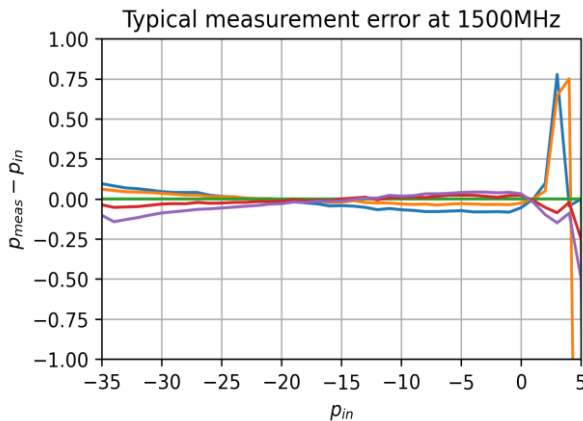
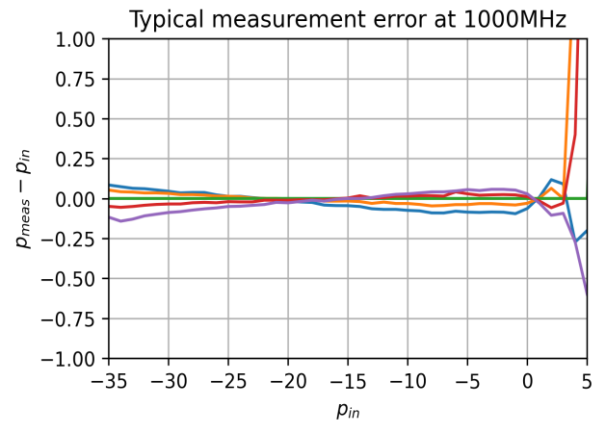
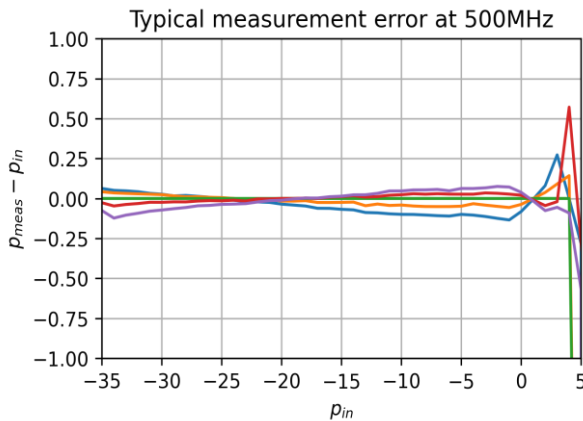
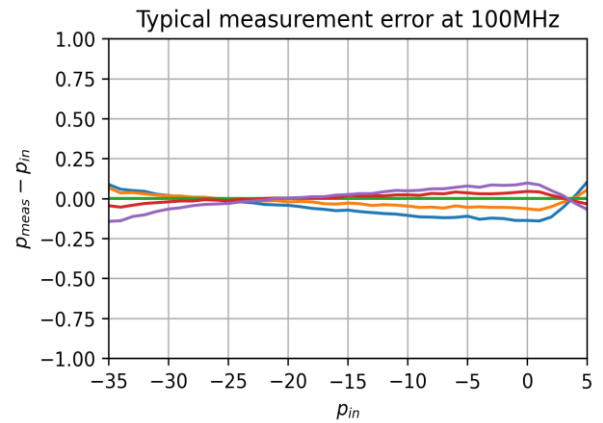

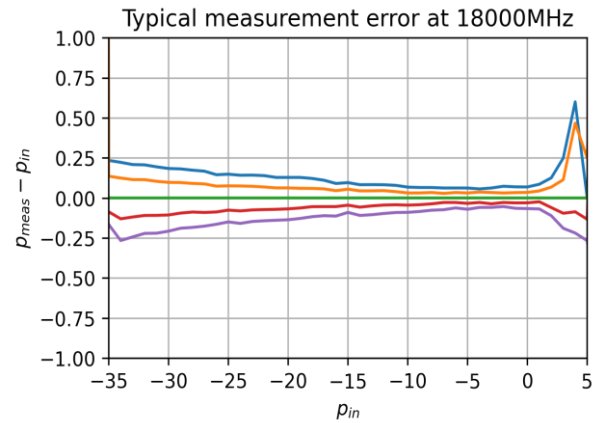
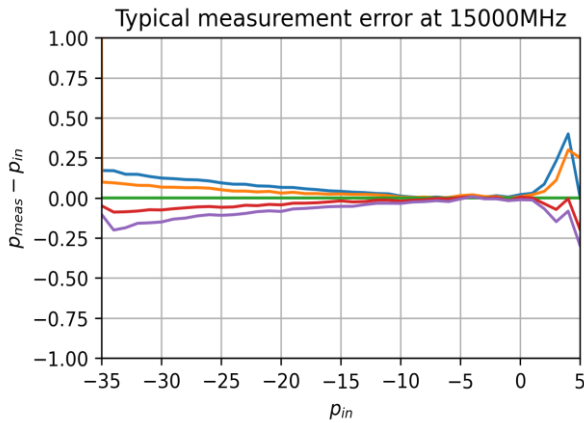
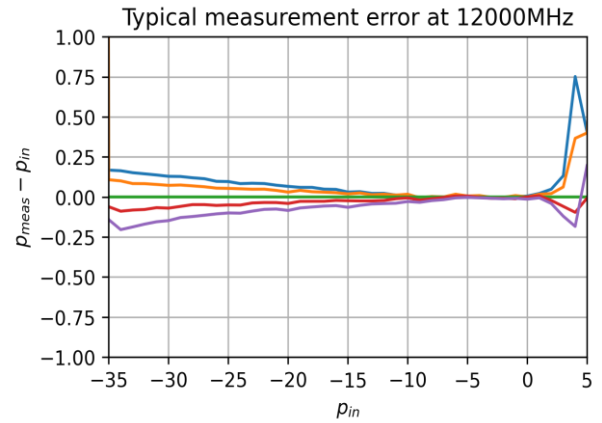
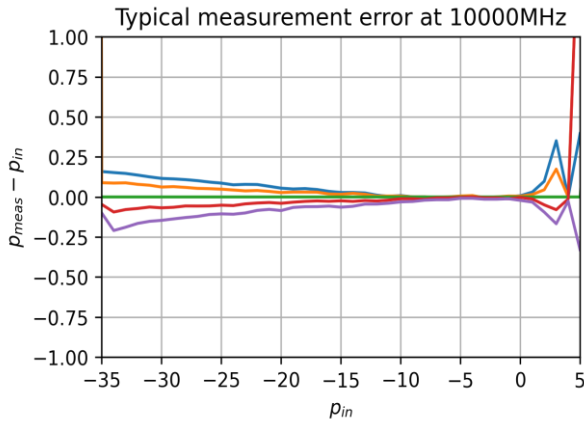
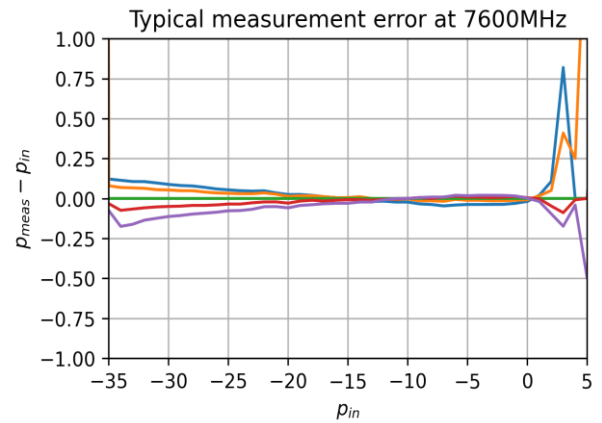
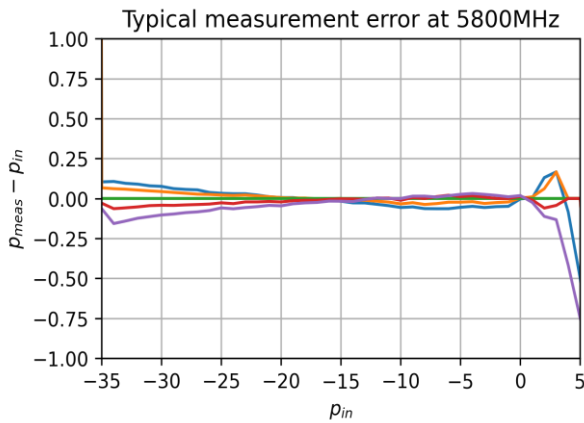
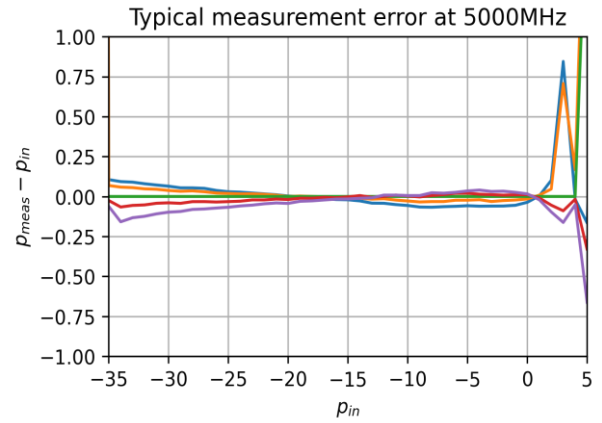
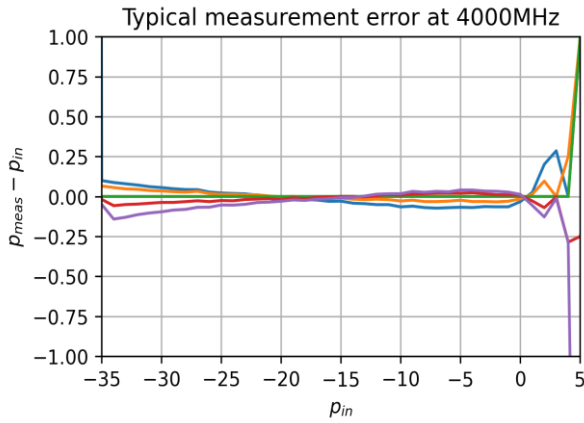

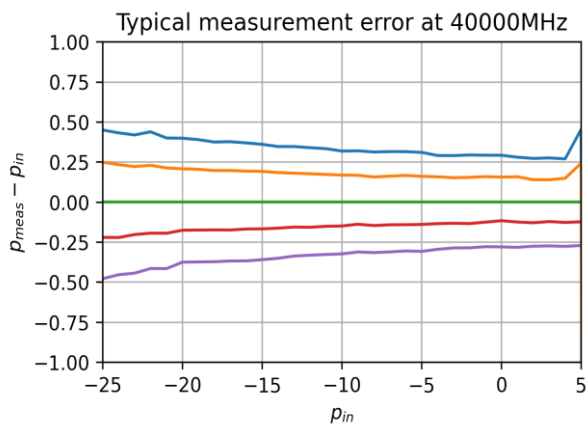
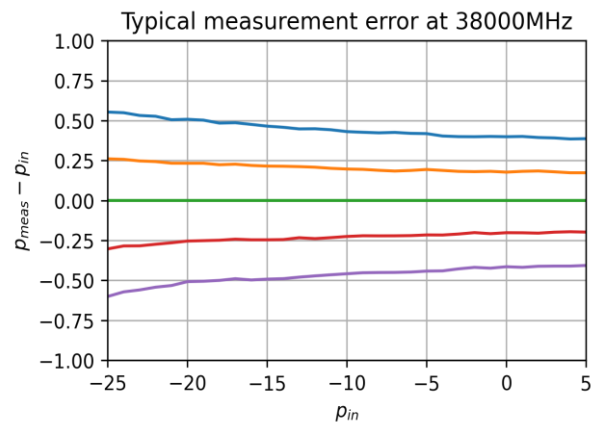
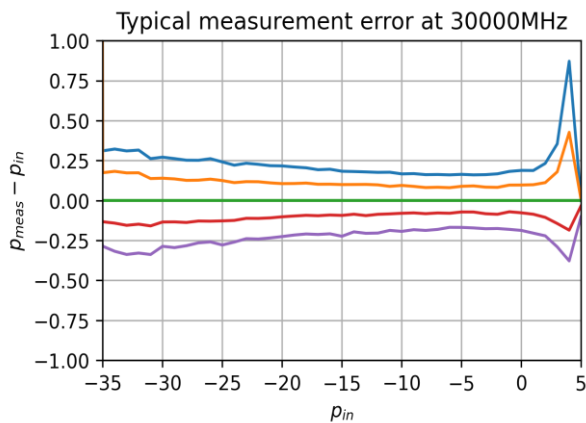
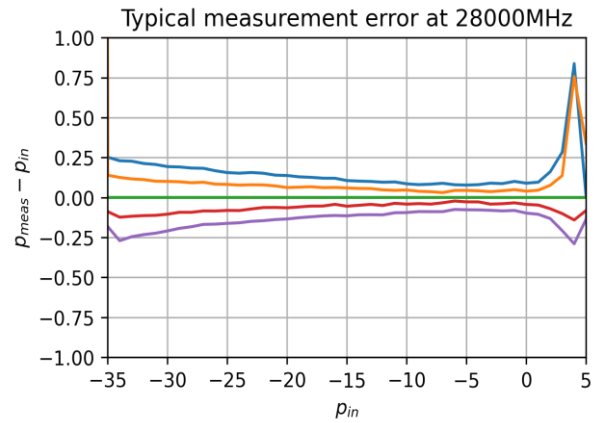
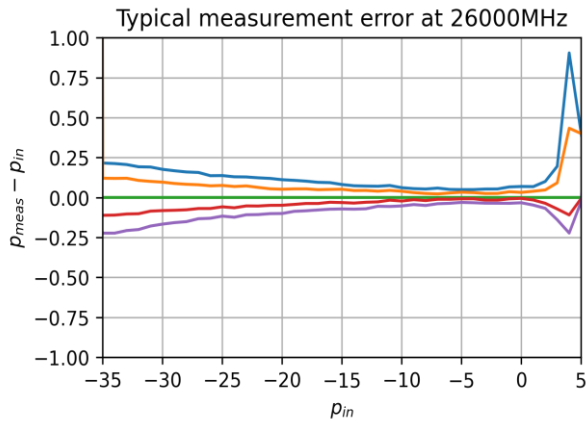
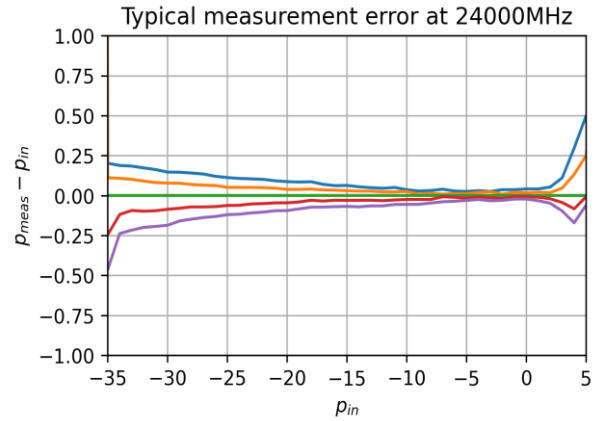
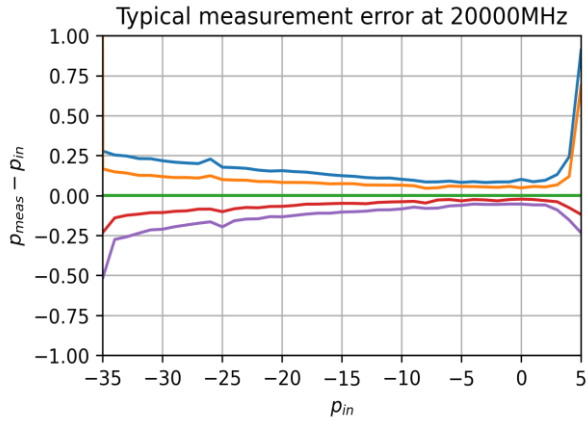

Notes

Copyright notice

This Product uses the following Open Source Packages and their respective dependencies:

Raspberry Pi OS Lite

Copyright RASPBERRY PI FOUNDATION

Please see <https://www.raspberrypi.org/software/operating-systems/> for details

NGINX

Copyright (C) 2002-2021 Igor Sysoev

Copyright (C) 2011-2021 Nginx, Inc. All rights reserved.

Redistribution and use in source and binary forms, with or without modification, are permitted provided that the following conditions are met:

1. Redistributions of source code must retain the above copyright notice, this list of conditions and the following disclaimer.
2. Redistributions in binary form must reproduce the above copyright notice, this list of conditions and the following disclaimer in the documentation and/or other materials provided with the distribution.

THIS SOFTWARE IS PROVIDED BY THE AUTHOR AND CONTRIBUTORS "AS IS" AND ANY EXPRESS OR IMPLIED WARRANTIES, INCLUDING, BUT NOT LIMITED TO, THE IMPLIED WARRANTIES OF MERCHANTABILITY AND FITNESS FOR A PARTICULAR PURPOSE ARE DISCLAIMED. IN NO EVENT SHALL THE AUTHOR OR CONTRIBUTORS BE LIABLE FOR ANY DIRECT, INDIRECT, INCIDENTAL, SPECIAL, EXEMPLARY, OR CONSEQUENTIAL DAMAGES (INCLUDING, BUT NOT LIMITED TO, PROCUREMENT OF SUBSTITUTE GOODS OR SERVICES; LOSS OF USE, DATA, OR PROFITS; OR BUSINESS INTERRUPTION) HOWEVER CAUSED AND ON ANY THEORY OF LIABILITY, WHETHER IN CONTRACT, STRICT LIABILITY, OR TORT (INCLUDING NEGLIGENCE OR OTHERWISE) ARISING IN ANY WAY OUT OF THE USE OF THIS SOFTWARE, EVEN IF ADVISED OF THE POSSIBILITY OF SUCH DAMAGE.

Python 3.7.2

PSF LICENSE AGREEMENT FOR PYTHON 3.7.2

1. This LICENSE AGREEMENT is between the Python Software Foundation ("PSF"), and the Individual or Organization ("Licensee") accessing and otherwise using Python 3.7.2 software in source or binary form and its associated documentation.
2. Subject to the terms and conditions of this License Agreement, PSF hereby grants Licensee a nonexclusive, royalty-free, world-wide license to reproduce, analyze, test, perform and/or display publicly, prepare derivative works, distribute, and otherwise use Python 3.7.2 alone or in any derivative version, provided, however, that PSF's License Agreement and PSF's notice of copyright, i.e., "Copyright © 2001-2019 Python Software Foundation; All Rights Reserved" are retained in Python 3.7.2 alone or in any derivative version prepared by Licensee.
3. In the event Licensee prepares a derivative work that is based on or incorporates Python 3.7.2 or any part thereof, and wants to make the derivative work available to others as provided herein, then Licensee hereby agrees to include in any such work a brief summary of the changes made to Python 3.7.2.
4. PSF is making Python 3.7.2 available to Licensee on an "AS IS" basis. PSF MAKES NO REPRESENTATIONS OR WARRANTIES, EXPRESS OR IMPLIED. BY WAY OF EXAMPLE, BUT NOT LIMITATION, PSF MAKES NO AND DISCLAIMS ANY REPRESENTATION OR WARRANTY OF MERCHANTABILITY OR FITNESS FOR ANY PARTICULAR PURPOSE OR THAT THE USE OF PYTHON 3.7.2 WILL NOT INFRINGE ANY THIRD PARTY RIGHTS.
5. PSF SHALL NOT BE LIABLE TO LICENSEE OR ANY OTHER USERS OF PYTHON 3.7.2 FOR ANY INCIDENTAL, SPECIAL, OR CONSEQUENTIAL DAMAGES OR LOSS AS A RESULT OF MODIFYING, DISTRIBUTING, OR OTHERWISE USING PYTHON 3.7.2, OR ANY DERIVATIVE THEREOF, EVEN IF ADVISED OF THE POSSIBILITY THEREOF.
6. This License Agreement will automatically terminate upon a material breach of its terms and conditions.
7. Nothing in this License Agreement shall be deemed to create any relationship of agency, partnership, or joint venture between PSF and Licensee. This License Agreement does not grant permission to use PSF trademarks or trade name in a trademark sense to endorse or promote products or services of Licensee, or any third party.
8. By copying, installing or otherwise using Python 3.7.2, Licensee agrees to be bound by the terms and conditions of this License Agreement.

Flask

Copyright 2010 Pallets

1. Redistribution and use in source and binary forms, with or without modification, are permitted provided that the following conditions are met:

2. Redistributions of source code must retain the above copyright notice, this list of conditions and the following disclaimer.
3. Redistributions in binary form must reproduce the above copyright notice, this list of conditions and the following disclaimer in the documentation and/or other materials provided with the distribution.

Neither the name of the copyright holder nor the names of its contributors may be used to endorse or promote products derived from this software without specific prior written permission. THIS SOFTWARE IS PROVIDED BY THE COPYRIGHT HOLDERS AND CONTRIBUTORS "AS IS" AND ANY EXPRESS OR IMPLIED WARRANTIES, INCLUDING, BUT NOT LIMITED TO, THE IMPLIED WARRANTIES OF MERCHANTABILITY AND FITNESS FOR A PARTICULAR PURPOSE ARE DISCLAIMED. IN NO EVENT SHALL THE COPYRIGHT HOLDER OR CONTRIBUTORS BE LIABLE FOR ANY DIRECT, INDIRECT, INCIDENTAL, SPECIAL, EXEMPLARY, OR CONSEQUENTIAL DAMAGES (INCLUDING, BUT NOT LIMITED TO, PROCUREMENT OF SUBSTITUTE GOODS OR SERVICES; LOSS OF USE, DATA, OR PROFITS; OR BUSINESS INTERRUPTION) HOWEVER CAUSED AND ON ANY THEORY OF LIABILITY, WHETHER IN CONTRACT, STRICT LIABILITY, OR TORT (INCLUDING NEGLIGENCE OR OTHERWISE) ARISING IN ANY WAY OUT OF THE USE OF THIS SOFTWARE, EVEN IF ADVISED OF THE POSSIBILITY OF SUCH DAMAGE.

Bokeh

Copyright (c) 2012 - 2021, Anaconda, Inc., and Bokeh Contributors

All rights reserved.

Redistribution and use in source and binary forms, with or without modification, are permitted provided that the following conditions are met:

- Redistributions of source code must retain the above copyright notice, this list of conditions and the following disclaimer.
- Redistributions in binary form must reproduce the above copyright notice, this list of conditions and the following disclaimer in the documentation and/or other materials provided with the distribution.

Neither the name of Anaconda nor the names of any contributors may be used to endorse or promote products derived from this software without specific prior written permission. THIS SOFTWARE IS PROVIDED BY THE COPYRIGHT HOLDERS AND CONTRIBUTORS "AS IS" AND ANY EXPRESS OR IMPLIED WARRANTIES, INCLUDING, BUT NOT LIMITED TO, THE IMPLIED WARRANTIES OF MERCHANTABILITY AND FITNESS FOR A PARTICULAR PURPOSE ARE DISCLAIMED. IN NO EVENT SHALL THE COPYRIGHT OWNER OR CONTRIBUTORS BE LIABLE FOR ANY DIRECT, INDIRECT, INCIDENTAL, SPECIAL, EXEMPLARY, OR CONSEQUENTIAL DAMAGES (INCLUDING, BUT NOT LIMITED TO, PROCUREMENT OF SUBSTITUTE GOODS OR SERVICES; LOSS OF USE, DATA, OR PROFITS; OR BUSINESS INTERRUPTION) HOWEVER CAUSED AND ON ANY THEORY OF LIABILITY, WHETHER IN CONTRACT, STRICT LIABILITY, OR TORT (INCLUDING NEGLIGENCE OR OTHERWISE) ARISING IN ANY WAY OUT OF THE USE OF THIS SOFTWARE, EVEN IF ADVISED OF THE POSSIBILITY OF SUCH DAMAGE.

SciPy

Copyright © 2001, 2002 Enthought, Inc.

All rights reserved.

Copyright © 2003-2019 SciPy Developers.

All rights reserved.

Redistribution and use in source and binary forms, with or without modification, are permitted provided that the following conditions are met:

- Redistributions of source code must retain the above copyright notice, this list of conditions and the following disclaimer.
- Redistributions in binary form must reproduce the above copyright notice, this list of conditions and the following disclaimer in the documentation and/or other materials provided with the distribution.

Neither the name of Enthought nor the names of the SciPy Developers may be used to endorse or promote products derived from this software without specific prior written permission. THIS SOFTWARE IS PROVIDED BY THE COPYRIGHT HOLDERS AND CONTRIBUTORS "AS IS" AND ANY EXPRESS OR IMPLIED WARRANTIES, INCLUDING, BUT NOT LIMITED TO, THE IMPLIED WARRANTIES OF MERCHANTABILITY AND FITNESS FOR A PARTICULAR PURPOSE ARE DISCLAIMED. IN NO EVENT SHALL THE REGENTS OR CONTRIBUTORS BE LIABLE FOR ANY DIRECT, INDIRECT, INCIDENTAL, SPECIAL, EXEMPLARY, OR CONSEQUENTIAL DAMAGES (INCLUDING, BUT NOT LIMITED TO, PROCUREMENT OF SUBSTITUTE GOODS OR SERVICES; LOSS OF USE, DATA, OR PROFITS; OR BUSINESS INTERRUPTION) HOWEVER CAUSED AND ON ANY THEORY OF LIABILITY, WHETHER IN CONTRACT, STRICT LIABILITY, OR TORT (INCLUDING NEGLIGENCE OR OTHERWISE) ARISING IN ANY WAY OUT OF THE USE OF THIS SOFTWARE, EVEN IF ADVISED OF THE POSSIBILITY OF SUCH DAMAGE.